

## DISCONNECT SWITCHES (10-2698 AND 10-2699)



### Features

- Stainless steel faceplate with etched text
- Two-position key switch removable only in ARMED position
- With or without status indicator LEDs
- Surface or flush mounted

### Description

The Disconnect Switch provides a means to disconnect the releasing circuit to the suppression system in order to avoid an unwanted discharge during service, maintenance or testing of the system.

NFPA 2001 requires that a disconnect switch be provided on all electrically actuated clean agent systems and requires the switch to initiate a supervisory signal at the releasing control panel upon activation.

### Specifications

Input Voltage	15 – 30 VDC
Current Consumption	13.1 mA (LED active)
Circuit Limitations	Class B only
Weight	0.55 lb. (0.25 kg)
Operating Temp.	0 to 49°C (32 to 120°F)
Operating Humidity	93% RH
Contact Rating	8A @ 24 VDC Resistive 4A @ 24 VDC Inductive
Mounting	Surface or Flush
Compatible Releasing Devices	Agent Release Module (ARM), P/N 10-1832
	Impulse Release Module (IRM), P/N 10-2748
	Universal Valve Operator (UVO), P/N 02-13571
	Direct Fire Impulse Actuator (DFIA), P/N 02-13279
	Releasing solenoids. Refer to Fike Device Compatibility document P/N 06-186.

### Approvals

Underwriters Laboratories (UL)  
 Factory Mutual (FM)  
 California State Fire Marshal (CSFM)  
 New York Certificate of Approval (COA)

*For exact certification listings, please reference the respective agency web site.*

This document is only intended to be a guideline and is not applicable to all situations. Information is subject to Fike's full disclaimer at <http://www.fike.com/disclaimer>.

## Ordering Information

Part Number	Description
10-2698	Disconnect Switch, no LED's
10-2699	Disconnect Switch, with LED's
02-2153	Two gang x 2.5" deep (Raco 691) masonry box; fits P/N 10-2698
02-11881	Two gang x 3" deep (Raco 696) masonry box; fits P/N 10-2699
<b>Replacement Parts</b>	
02-12294	Double contact block (2 NC)
02-12295	Double contact block (2 NO)
02-12296	Replacement keys
02-12298	5 block switch (contacts and switch)
02-12300	Single contact (NO)
02-12315	3 block switch (contacts and switch)
02-12316	Single contact block (NC)
02-12318	Locking ring wrench
10-2714	Cover plate w/o LED holes

## Dimensions

Required depth of mounting box varies between switch with or without LEDs.

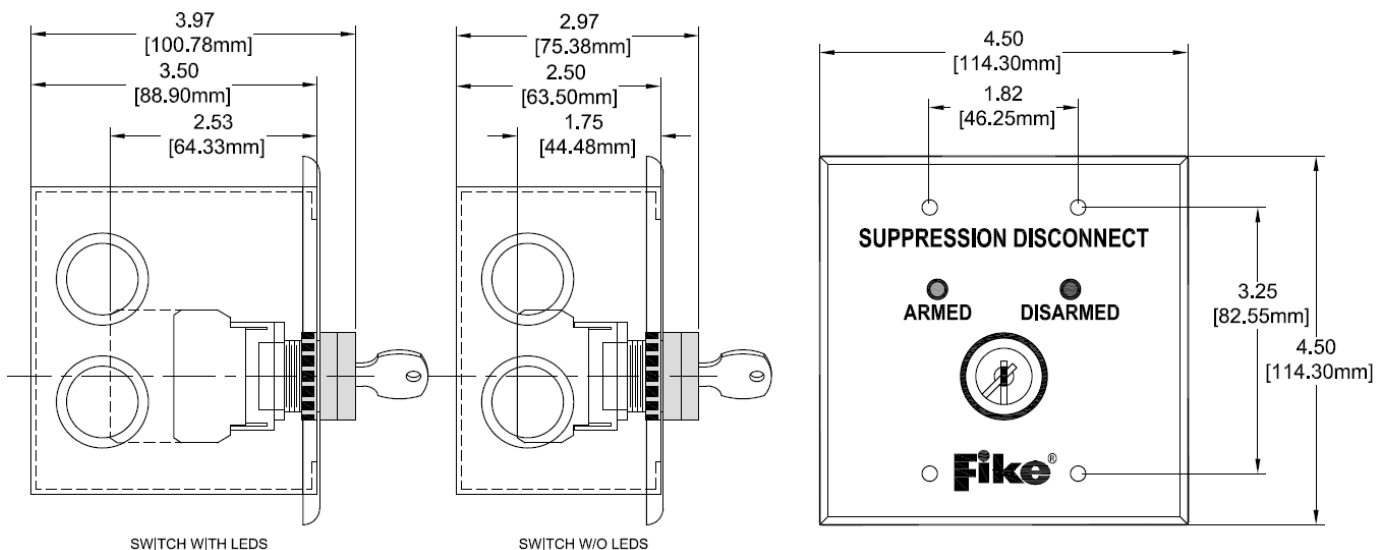

This document is only intended to be a guideline and is not applicable to all situations. Information is subject to Fike's full disclaimer at <http://www.fike.com/disclaimer>.